

TAPERED END MILLS

SPECIAL TOOLS MANUFACTURED IN MELBOURNE

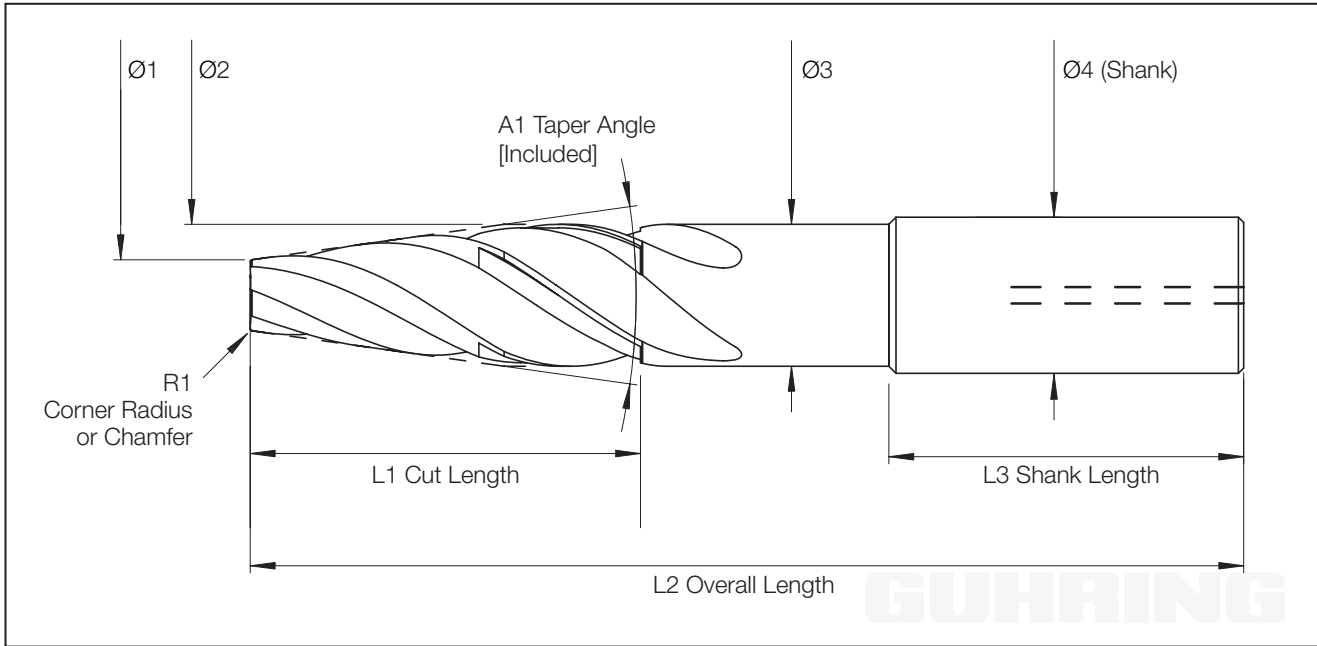

$\varnothing 1$ - Lead Diameter _____
 $\varnothing 2$ - Nominal Diameter _____
 $\varnothing 3$ - Neck Diameter _____
 $\varnothing 4$ - Shank Diameter _____
 L1 - Cut Length _____
 L2 - Overall Length _____
 L3 - Shank Length _____
 A1 - Taper Angle _____
 A3 - Helix Angle _____
 Z - Number Of Flutes _____
 R1 - Corner Radius _____

Internal Coolant Yes
 No

 Surface Uncoated
 TiN
 FIRE
 ICE
 ZENIT

 End Cutting YES
 NO

(or) Corner Chamfer: _____ Degrees x _____ mm

Quantities for quotation:
 Quantity 1. _____ pieces
 Quantity 2. _____ pieces
 Quantity 3. _____ pieces

COMPANY	NAME	DATE
ADDRESS		
PHONE	FAX	EMAIL

1 Miles Street, Mulgrave, VIC 3170 FAX: (03) 9948 4699 E-MAIL: guhring@guhring.com.au

This drawing is the property of Guhring oHG. It is not allowed to copy it partially or completely, to publish it, or to use or communicate it for the purpose of competition without authorization.